

Class 300 Bronze Globe Valves

Union Bonnet • Replaceable Seat and Full Plug Disc

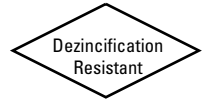

300 PSI/20.7 Bar Saturated Steam to 421° F/216° C
600 PSI/41.4 Bar Non-Shock Cold Working Pressure

CONFORMS TO MSS SP-80

MATERIAL LIST

PART	SPECIFICATION
1. Handwheel Nut	300 Series Stainless Steel
2. Identification Plate	Aluminum
3. Handwheel	Malleable Iron ASTM A 47
4. Stem	Silicon Bronze ASTM B 371 Alloy C69400/C69430
5. Packing Gland	Bronze ASTM B 62 or ASTM B584 Alloy C84400 or Brass ASTM B16
6. Packing Nut	Bronze ASTM B 62 or ASTM B584 Alloy C84400 or Brass ASTM B 16
7. Packing	Aramid Fibers with Graphite
8. Bonnet	Bronze ASTM B 61
9. Union Nut	Bronze ASTM B 61
10. Body	Bronze ASTM B 61
11. Disc Holder Nut	Bronze ASTM B 61
12. Plug Disc	S42000 Stainless Steel ASTM A276 Hardened
13. Plug Seat Ring	S42000 Stainless Steel ASTM A276 Hardened



T-276-AP
Threaded

DIMENSIONS—WEIGHTS—QUANTITIES

Size	Dimensions				Weight		Master Ctn. Qty.	
	In.	mm.	A In.	B mm.	Lbs.	Kg.		
† ¼	8†	2.63	67	4.44	113	1.34	0.61	50
† ⅜	10†	2.63	67	4.44	113	1.35	0.61	50
½	15	2.69	68	4.88	124	1.82	0.83	30
¾	20	3.38	86	5.75	146	2.88	1.30	20
1	25	4.00	102	7.00	178	4.77	2.16	10
1 ¼	32	4.63	118	7.63	194	6.96	3.16	10
1 ½	40	5.00	127	7.69	195	8.41	3.81	6
2	50	6.00	153	9.25	235	13.41	6.08	4
2 ½	65	6.63	168	10.19	259	17.59	7.98	2
3	80	7.75	197	11.13	283	24.55	11.13	2

† No packing gland, packing only in these sizes.

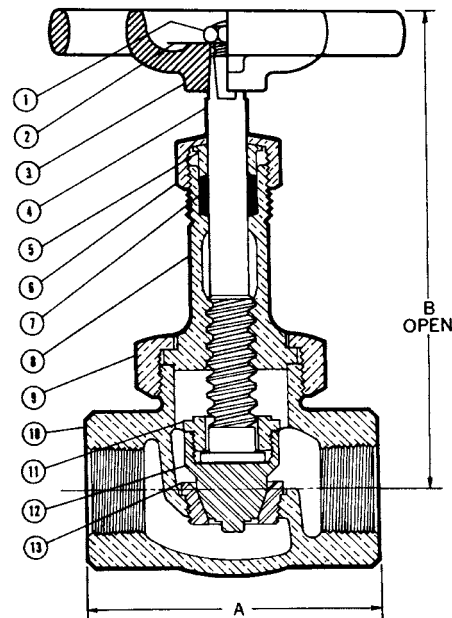

T-276-AP
NPT x NPT
Full Plug

FREEZING WEATHER PRECAUTION: Subsequent to testing a piping system, valves should be left in an open position to allow complete drainage.

◆ For detailed Operating Pressure, refer to Pressure Temperature Chart on page 114.

Visit our website for the most current information.