

NIBCO® Press System Lead-Free* Brass Ball Valves

Features: Press End Leak Detection • Solder Union • Two-Piece Body • PTFE Seats • Full Port • Blowout-Proof Stem

Approvals: IAPMO/ANSI Z1157 (IGC-157) • NSF/ANSI-61 & 372 • MSS SP-145 • Conforms to ASME B16.51†

Size range: 1/2" - 1"

Pressure rating: 250 PSI non-shock cold working pressure

Maximum pressure / temperature: 225 PSI at 250° F

Lead-Free* markings:

White handle and blue hang tag

Applications: Drinking Water • Domestic Hot & Cold Water • HVAC (condensers, chilled water, hot water heating) • Isolation and Throttling (half-open to full-open only) • Connect to Rigid Copper Tubing Manufactured per ASTM B88, Condition H (hard drawn)

Reference Press System catalog for updated Approved Tool and Jaw Compatibility Matrix list.

Not intended for steam or gas usage.



PCSU-FP-600A-LF

Press x Solder Union
1/2" - 1"

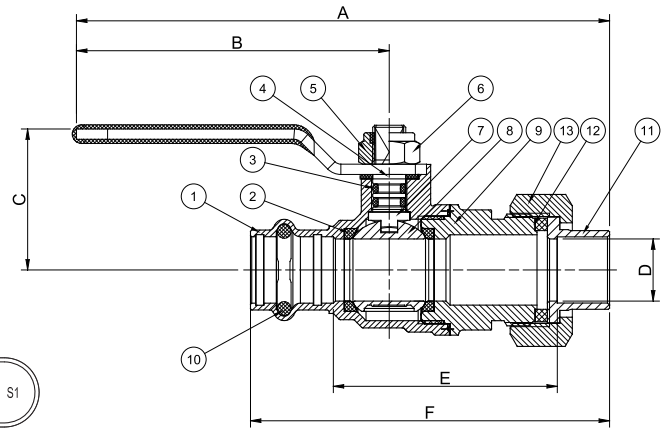

PCSU-FP-600A-LF

Press x Solder Union
1/2" - 1"

MATERIAL LIST

PART	SPECIFICATION
1. Body	Forged DZR Copper Alloy - C46500
2. Seat Seal	PTFE
3. O-ring	EPDM - ASTM D2000
4. Washer	PTFE
5. Lock Nut	Stainless Steel + Nylon
6. Handle	Steel, Plated
7. Stem	Brass
8. Ball	Chrome Plated Brass - C46500
9. End Cap	Forged DZR Copper Alloy - C46500
10. O-ring	EPDM - ASTM D2000
11. Fitting	Forged DZR Copper Alloy - C46500
12. Washer	EPDM
13. Nut	Brass

Options:

- Extended lever
- EPDM Seal for Press Ends
- Wing Handle



Handle Markings

DIMENSIONS—WEIGHTS—QUANTITIES

SIZE		A		B		C		D		E		F		Weight	
In.	mm.	In.	mm.	In.	mm.	In.	mm.	In.	mm.	In.	mm.	In.	mm.	Lbs.	Kg.
1/2	12.7	5.72	145.20	3.62	92.00	1.34	34.00	0.59	15.00	2.13	54.10	3.41	86.70	0.6130	0.2780
3/4	19.05	6.64	168.70	4.13	105.00	2.06	52.20	0.79	20.00	2.44	62.10	4.10	104.20	1.0010	0.4540
1	25.40	6.90	175.20	4.13	105.00	2.21	56.20	0.98	25.00	2.68	68.10	4.50	114.20	1.4880	0.6749

IAPMO/ANSI Z1157: in addition to meeting IGC-157 test requirements, the IAPMO/ANSI Z1157 also requires Press ends to be fully tested to IAPMO PS-117 performance requirements which includes the following additional tests:

- | | |
|--|--|
| 1. Unrestrained Hydrostatic Pressure Test at 20 °C (68°F) | 6. Hydraulic Shock (Water Hammer) Test |
| 2. Unrestrained Hydrostatic Pressure Test at 93 °C (200°F) | 7. Vibration Test |
| 3. Static Torsion Test for Press Connections | 8. Thermal Cycling Test |
| 4. Bending Test | 9. Alternate Thermal Cycling Test |
| 5. Vacuum Test | 10. Dynamic Torsion Test for Press Connections |

†Tested to the performance criteria of ASME B16.51