

NIBCO® Press System Lead-Free* Brass Ball Valves

Features: Press End Leak Detection • FIP Union • Two-Piece Body • PTFE Seats • Full Port • Blowout-Proof Stem

Approvals: IAPMO/ANSI Z1157 (IGC-157) • NSF/ANSI-61 & 372 • MSS SP-145 • Conforms to ASME B16.51†

Size range: 1/2" - 1"

Pressure rating: 250 PSI non-shock cold working pressure

Maximum pressure / temperature: 225 PSI at 250° F

Lead-Free* markings:

White handle and blue hang tag

Applications: Drinking Water • Domestic Hot & Cold Water • HVAC (condensors, chilled water, hot water heating) • Isolation and Throttling (half-open to full-open only) • Connect to Rigid Copper Tubing Manufactured per ASTM B88, Condition H (hard drawn)

Reference Press System catalog for updated Approved Tool and Jaw Compatibility Matrix list.

Not intended for steam or gas usage.



PCFU-FP-600A-LF

Press x FIP Union
1/2" - 1"

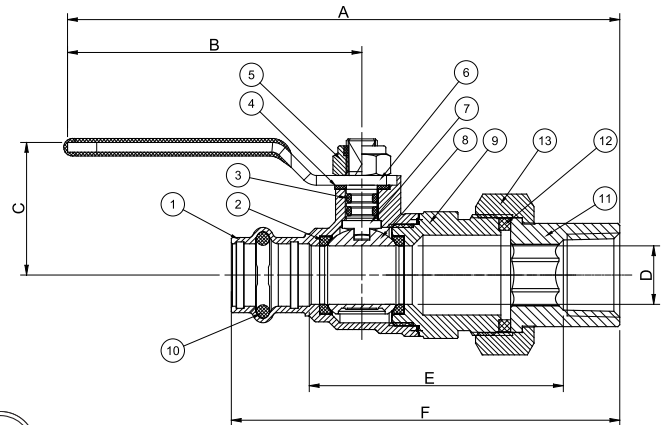

PCFU-FP-600A-LF
Press x FIP Union
1/2" - 1"

MATERIAL LIST

PART	SPECIFICATION
1. Body	Forged DZR Copper Alloy - C46500
2. Seat Seal	PTFE
3. O-ring	EPDM - ASTM D2000
4. Washer	PTFE
5. Lock Nut	Stainless Steel + Nylon
6. Handle	Steel, Plated
7. Stem	Brass
8. Ball	Chrome Plated Brass - C46500
9. End Cap	Forged DZR Copper Alloy - C46500
10. O-ring	EPDM - ASTM D2000
11. Fitting	Forged DZR Copper Alloy - C46500
12. Washer	EPDM
13. Nut	Brass

Options:

- Extended lever
- EPDM Seal for Press Ends
- Wing Handle



Handle Markings

DIMENSIONS—WEIGHTS—QUANTITIES

SIZE		A		B		C		D		E		F		Weight	
In.	mm.	In.	mm.	In.	mm.	In.	mm.	In.	mm.	In.	mm.	In.	mm.	Lbs.	Kg.
1/2	12.7	6.23	158.20	3.62	92.00	1.34	34.00	0.59	15.00	2.57	65.20	3.93	99.70	0.7720	0.3501
3/4	19.05	6.92	175.70	4.13	105.00	2.06	52.20	0.79	20.00	2.84	72.20	4.38	111.20	1.2040	0.5461
1	25.40	7.17	182.20	4.13	105.00	2.21	56.20	0.98	25.00	3.11	79.00	4.77	121.20	1.7750	0.8051

IAPMO/ANSI Z1157: in addition to meeting IGC-157 test requirements, the IAPMO/ANSI Z1157 also requires Press ends to be fully tested to IAPMO PS-117 performance requirements which includes the following additional tests:

- | | |
|--|--|
| 1. Unrestrained Hydrostatic Pressure Test at 20 °C (68°F) | 6. Hydraulic Shock (Water Hammer) Test |
| 2. Unrestrained Hydrostatic Pressure Test at 93 °C (200°F) | 7. Vibration Test |
| 3. Static Torsion Test for Press Connections | 8. Thermal Cycling Test |
| 4. Bending Test | 9. Alternate Thermal Cycling Test |
| 5. Vacuum Test | 10. Dynamic Torsion Test for Press Connections |

† Tested to the performance criteria of ASME B16.51

*Weighted average lead content ≤ 0.25%