

Lead-Free* Bronze Check Valves

Silicon Performance Bronze™ Alloy • Horizontal Swing • Regrinding Type • Y-Pattern • Renewable Seat and Disc • Conforms to MSS SP-139 • Press Ends • NSF/ANSI-61-8 Commercial Hot 180°F (includes Annex F and G) and NSF/ANSI-372

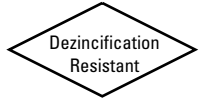

NSF/ANSI 61
NSF/ANSI 372



Size Range: 1/2" - 2"

Pressure Rating: 200 PSI Non-Shock Cold Working Pressure

Maximum Pressure / Temperature: 100 PSI at 250° F

Lead-Free* marking:

Double oval in body casting

MATERIAL LIST

PART	SPECIFICATION
1. Bonnet	Silicon Bronze ASTM B584 Alloy C87850
2. Body	Silicon Bronze ASTM B584 Alloy C87850
3. Hinge Pin	ASTM A276 Alloy S31600 or ASTM A276 Alloy S30400
4. Disc Hanger	Silicon Bronze ASTM B584 Alloy C87850
5. Stainless Steel Nut (2)	ASTM F594 Alloy S31600 or ASTM F594 Alloy S30400
6. Disc Holder	Silicon Bronze ASTM B371 Alloy C69300
7. Seat Disc	PTFE
8. Hinge Pin Plug	ASTM B371 Alloy C69300
*9. Disc Washer	304 Stainless Steel
10. O-Ring	EPDM
11. Press End Adapter	ASTM B75 Alloy C12200
12. Crimp Evident Seal O-Ring	304SS or 316SS

*Sizes 3/4", 1", 1 1/4", 1 1/2" and 2" only

DIMENSIONS—WEIGHTS

SIZE	Dimensions				Master	Weight		
	A (Lay Length)		B (Height)					
In.	mm.	In.	mm.	In.	mm.	Ctn Qty	Lbs.	Kg.
1/2	15	2.78	71	1.66	42	40	0.72	0.33
3/4	20	3.25	83	1.90	48	40	1.13	0.51
1	25	3.97	101	2.27	58	25	1.80	0.82
1 1/4	32	4.64	118	2.67	68	20	2.42	1.10
1 1/2	40	5.00	127	3.09	79	16	3.75	1.70
2	50	5.85	149	3.84	98	4	6.02	2.73



PC413-Y-LF
Press Ends

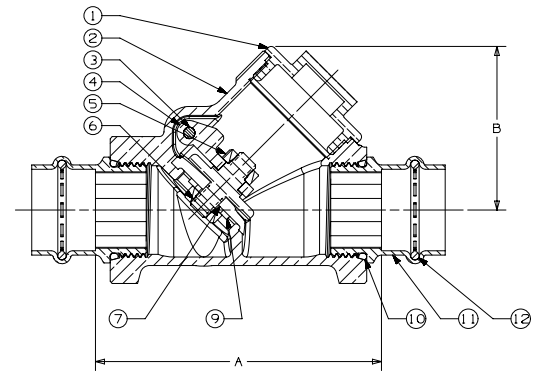

PC413-Y-LF
Press x Press

NIBCO check valves may be installed in both horizontal and vertical lines with upward flow or in any intermediate position.

They will operate satisfactorily in a declining plane (no more than 15°). Install check valves as far from pump discharge or line direction change as possible and at a minimum length of 5 times the pipe diameter.

Do not use for Reciprocating Air Compressor Service.

*Weighted average lead content ≤ 0.25%

Visit our website for the most current information.